



W.C. 29th June

<https://www.bbc.co.uk/bitesize/tags/zncsscw/year-6-lessons/1>

<https://whiterosemaths.com/homelearning/year-6/>

## Maths

Dear parents/carers, there is no expectation to complete all the work or print worksheets off - children can work on paper if they want to write it down. Thanks for all your hard work.

Also there is work on **StudyLadder** that we know the children love to use. You can email us on [s83year6@st-annes.solihull.sch.uk](mailto:s83year6@st-annes.solihull.sch.uk) for the password if your child has forgotten their login.

**Purple Mash** Look out for the activities:

There is a **Fluent in 5** at the start of **Monday to Thursday** for the children to practise their arithmetic.

We have also uploaded into the home learning section the **Corbett Maths 5** a day for the whole of **June and July** for each level - **Bronze, Silver, Gold, Platinum** (as well as the answers) and a **weekly arithmetic test with answers**.



After watching the videos and having a go at the practice activities, have a go at these activities. Depending on your confidence choose **Mild, Medium or Spicy**.

**Extensions** - You may wish to deepen your learning by looking at the **Collins Worksheets** provided by the BBC too.

## Ratio Language

For every 1 circle, there are 2 triangles.

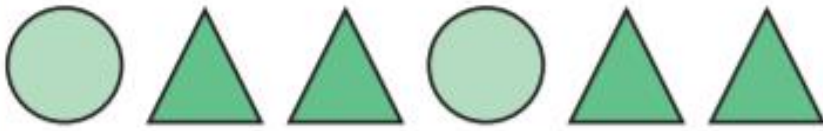

For every 2 bananas, there are 3 apples.



For every 1 football, there are 3 rugby balls.



## Ratio and Fractions



For every 1 rugby ball, there are 2 footballs.

Ratio of rugby balls to footballs: 1:2

$\frac{1}{3}$  of the balls are rugby balls.

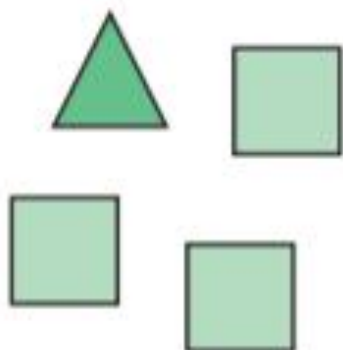

For every 1 triangle, there are 3 squares.

Ratio of triangles to squares: 1:3

$\frac{1}{4}$  of the shapes are triangles.

## The Ratio Symbol



The ratio of footballs to rugby balls: 1:4

The ratio of rugby balls to footballs: 4:1



The ratio of circles to triangles: 2:3

The ratio of triangles to circles: 3:2



The ratio of apples to bananas: 1:2

The ratio of bananas to oranges: 2:3

The ratio of apples to bananas to oranges: 1:2:3

The ratio of oranges to bananas to apples: 3:2:1

# Monday

<https://www.bbc.co.uk/bitesize/tags/zncsscw/year-6-lessons/1>

<https://whiterosemaths.com/homelearning/year-6/>

Introducing ratio, including the language and symbol

Fluent in 5

1	$490 \div 7 =$	
		
<input type="text"/>		<input type="checkbox"/> 1 mark

2	$675.32 - 138.83 =$	
		
<input type="text"/>		<input type="checkbox"/> 1 mark

3	$21 \overline{) 863}$	
		
<input type="text"/>		<input type="checkbox"/> 2 marks

4

$6 + 3 \times 6 =$

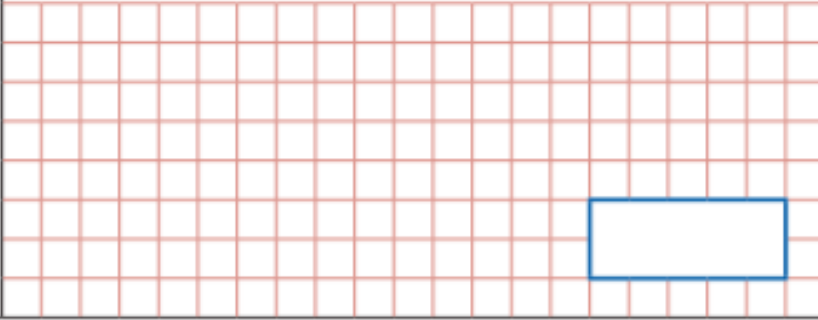

1 mark

5

$\frac{1}{3} + \frac{1}{6} =$

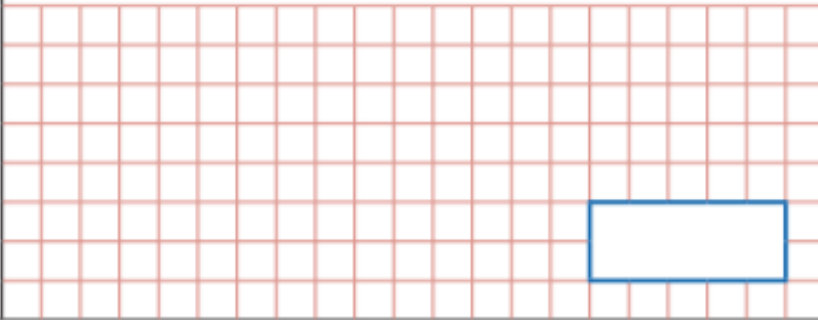

1 mark

6

$0.6 \div 0.2 =$

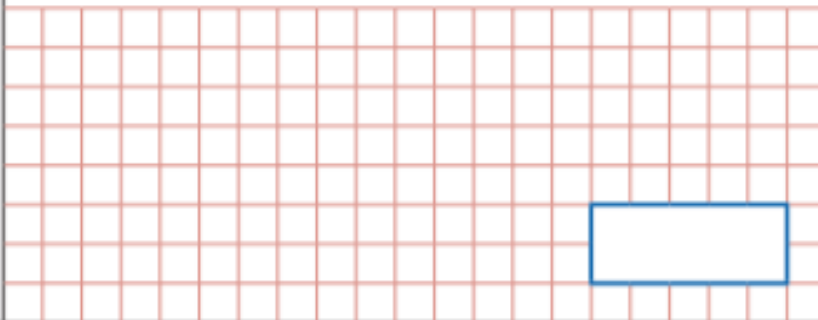



1 mark

## Mild

- 1 The ratios show shaded parts to non-shaded parts.

Match the ratios, statements and bar models.

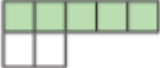
$2:3$	five to two	
$5:2$	three to two	
$2:5$	two to three	
$3:2$	two to five	

2



The ratio of purple to yellow is  $5:4$

Mo

It is  $4:5$



Alex

Who is correct? \_\_\_\_\_

Explain your answer.

- 3 Dani has some counters, cubes and marbles.

Complete the sentences.

The ratio of counters to marbles is  :

The ratio of marbles to cubes is  :

The ratio of cubes to counters is  :

The ratio of counters to cubes is  :

The ratio of counters to cubes to marbles is  :  :

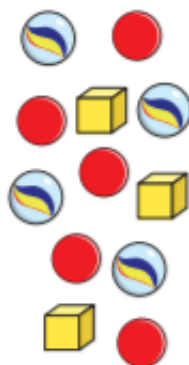

True or false? The ratio of cars to buses is  $3:7$ .



Match the cards to the correct image.

A. 1:9 pens to pencils



B. 4:1 pens to pencils

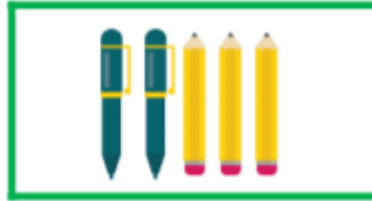

C. 3:2 pencils to pens



Circle the odd one out by matching the ratios to the description.



1:5

striped sock to spotty sock

5:1

spotty sock to striped sock

5:2

This machine turns sentences into ratios. Could this ratio be correct?

There are four times as many pears as oranges.



Convince me.

This machine turns sentences into ratios. Could this ratio be correct?

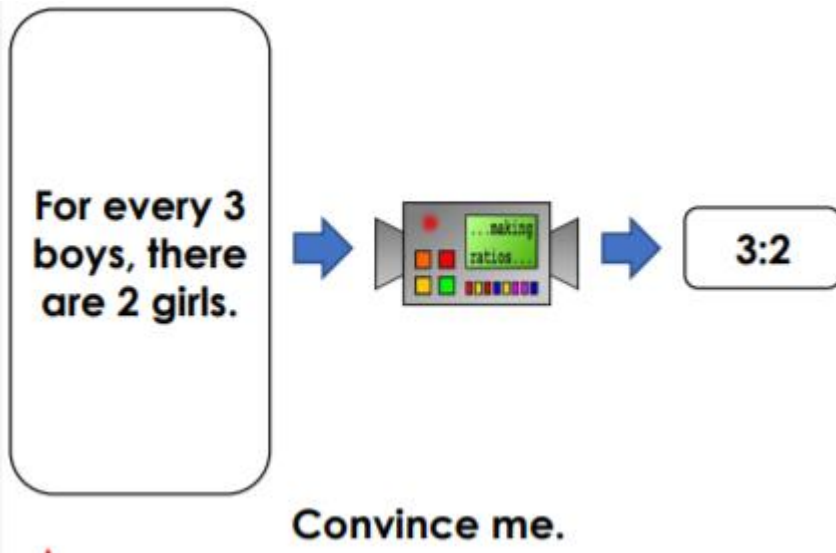

Each child's statement is correct.



Rishon

The ratio is 4:1.



Riva

The ratio is 1:4.



**Explain how this is possible.**

In a 10-piece fruit basket, there are only apples and pears. There are more apples than pears. Write down 3 solutions for the possible ratio of pears to apples. Draw counters to support your answers.

**Medium**

True or false? The ratio of bananas to apples is 4:3.



True or false? The ratio of snails to butterflies is 2:4.



Match the statements that mean the same thing.

A. 1:2 red counters to blue counters

1. There are twice as many blue counters as red counters.

B. 3:2 red counters to blue counters

2. For every 2 blue counters, there are 3 red counters.

C. 2:3 red counters to blue counters

3. For every 2 red counters, there are 3 blue counters.

Match the statements that mean the same thing.

A. 3:7 pens to pencils

1. There are four times as many pens as pencils.

B. 7:3 pens to pencils

2. For every 7 pens, there are 3 pencils.

C. 1:4 pencils to pens

3. For every 3 pens, there are 7 pencils.

Find the odd one out by matching the ratios to the description.



1:3

rings to necklaces to watches

1:3:2

rings to necklaces

3:2:1

Find the odd one out by matching the ratios to the description.



3:4:1

spotty to striped

3:4

striped to spotty to plain

4:3:1

Brett has drawn some triangles and squares.

The ratio of triangles to squares is 1:3

a) Are there more triangles or more squares? \_\_\_\_\_

Explain how you know.

b) Brett has drawn more than 10 shapes.

Draw what Brett might have drawn.

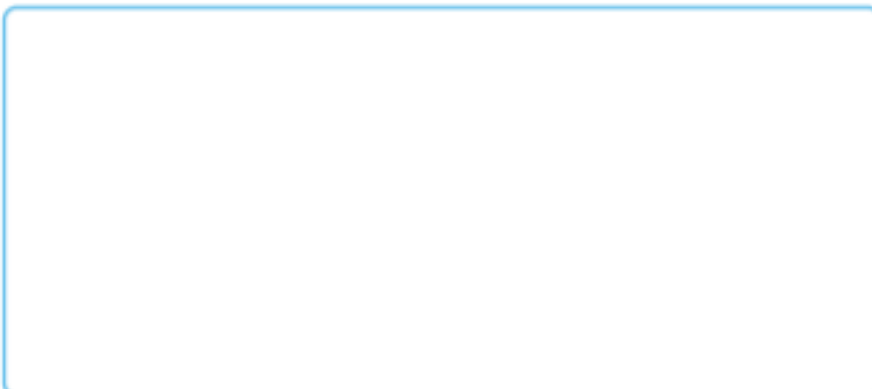

Here are some rulers and some pencils.

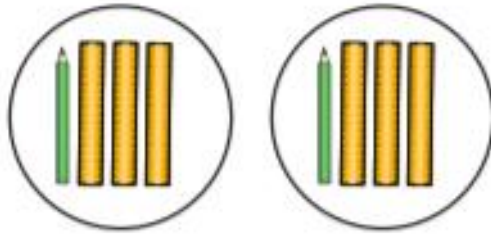

a) What is the ratio of pencils to rulers?

 : 

b) Here are some more rulers and pencils.

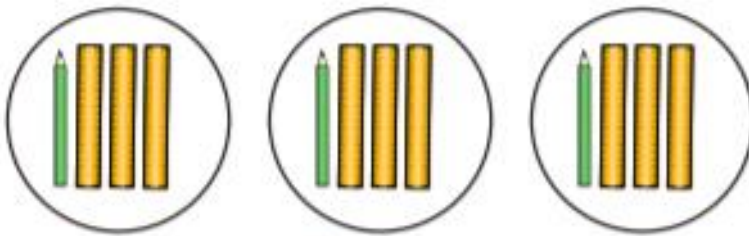

Ron

The ratio of pencils to rulers is the same as in part a).



Dora

Ron is wrong because there are more pencils and more rulers.

Who is correct? \_\_\_\_\_

Explain your answer.

This machine turns sentences into ratios. Could this ratio be correct?

There are twice as many pears as oranges. For every 2 oranges, there are 3 apples.



**Convince me.**

## Spicy

The ratio of horses to chickens in a field is 2:5

Here are the horses. Draw the chickens.



True or false? The ratio of rings to watches to necklaces is 2:1:3.



True or false? The ratio of cars to buses to lorries is 3:2:1.



Match the statements that mean the same thing.

A. 1:3:5 apples to oranges to pears

1. For every apple, there are 2 oranges and 4 pears.

B. 5:3:1 apples to pears to oranges

2. For every apple, there are 5 pears and 3 oranges.

C. 1:2:4 apples to oranges to pears

3. For every orange, there are 5 apples and 3 pears.

Match the statements that mean the same thing.

A. 3:5:1 teas to coffees to hot chocolates

1. For every tea, there are 5 hot chocolates and 4 coffees.

B. 1:4:5 teas to coffees to hot chocolates

2. For every tea, there are 5 hot chocolates and 3 coffees.

C. 5:1:3 hot chocolates to teas to coffees

3. For every hot chocolate, there are 3 teas and 5 coffees.

Find the odd one out by matching the ratios to the description.



3:2:1

cars to buses

2:3:1

buses to lorries to cars

1:3

Shade squares so that the ratio of shaded to non-shaded squares is 1:4

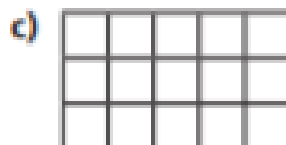
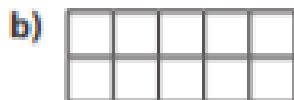

A box contains dark, white and milk chocolates.

$\frac{3}{8}$  of the box are dark chocolates.

$\frac{1}{2}$  of the box are milk chocolates.

The rest are white chocolates.

What does each ratio represent?

a) 1:3

---

b) 4:1

---

c) 3:5

---

This machine turns sentences into ratios. Could this ratio be correct?

There are three times as many pencils as rulers. For every 3 pencils, there are 2 rubbers.



**Convince me.**

Each child's statement is correct.



Cole

The ratio is 4:3.



Elise

The fraction is  $\frac{4}{13}$ .



Explain how this is possible.

Each child's statement is correct.



Rio

The ratio is 3:5.



Mave

The fraction is  $\frac{1}{2}$ .



Explain how this is possible.

9a. In a class of 30 children,  $\frac{3}{10}$  have a pet dog. The rest either have a pet cat or have no pets. More children have a pet than don't have a pet.

Write down 3 solutions for the possible ratio of dogs to cats to none.

## Tuesday

<https://www.bbc.co.uk/bitesize/tags/zncsscw/year-6-lessons/1>

<https://whiterosemaths.com/homelearning/year-6/>

### Represent and calculate ratio

#### Fluent in 5

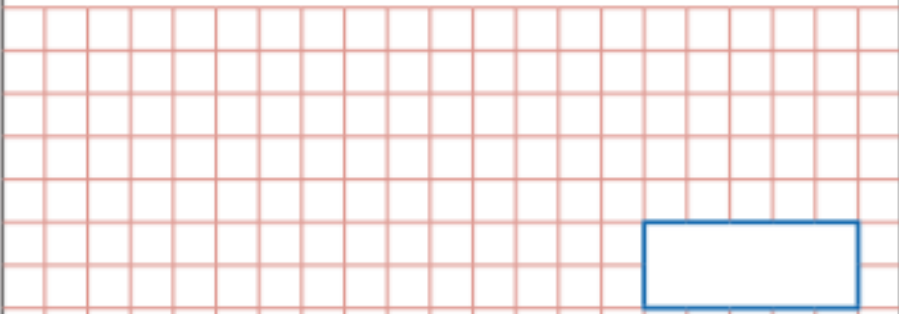
1	$1.2 \div 0.3 =$	
		
<input type="text"/>		<input type="checkbox"/> 1 mark

2	$64 + 130 =$	
		
<input type="text"/>		<input type="checkbox"/> 1 mark

3	$6 \times 3 - 2 \times 5 =$	
		
<input type="text"/>		<input type="checkbox"/> 1 mark

4

$$874.93 - 384.28 =$$

1 mark

5

$$5,432 \div 23 =$$

2 marks

6

$$\frac{3}{4} - \frac{1}{8} =$$

1 mark

## Mild

Continue the sequences, counting on in multiples of the first numbers to find equivalent ratios. The first one is done for you.

a.	1:2	2:4	3:6	4:8	5:10	6:12
b.	1:3	2:6	3:9			
c.	2:5	4:10				
d.	3:7	6:14				
e.	4:11					
f.	5:7					

1 Eva is baking cakes and cookies.

For every 1 cake, she will bake 2 cookies.



a) If Eva bakes 3 cakes, how many cookies will she bake?

b) If Eva bakes 10 cookies, how many cakes will she bake?

2 The ratio of red to yellow counters is 2:3

There are 20 counters in total.

How many counters of each colour are there?

You can colour the counters to help you.

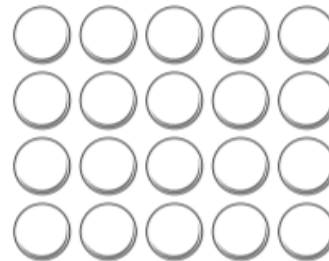

yellow

red

3 Tom has 5 green cubes for every 3 yellow cubes.

He has 16 cubes in total.

Draw a diagram to represent this.

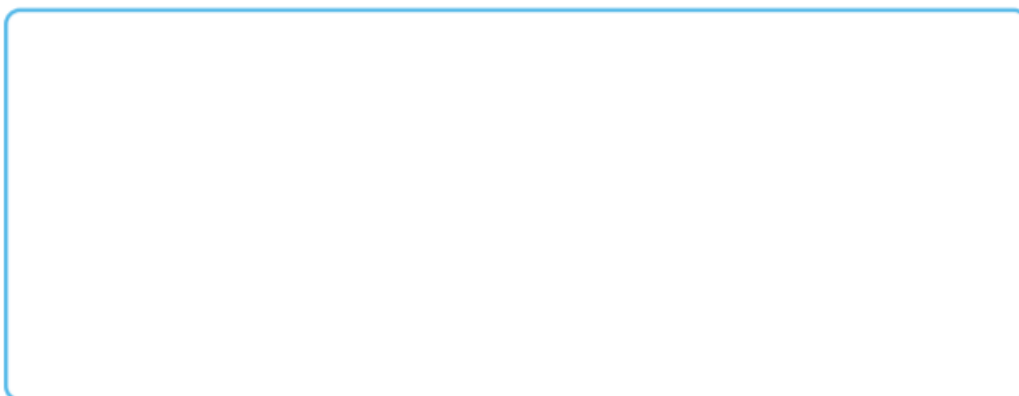

## Medium

For each grid, write the ratio as you see it then write the ratio in its simplest form. Show your working out. The first one is done for you.

a.

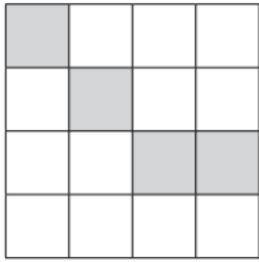

shaded to blank

4:12

$\div 4 = 1$

$\div 4 = 3$

1:3

b.

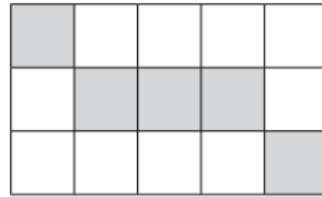

shaded to blank

c.

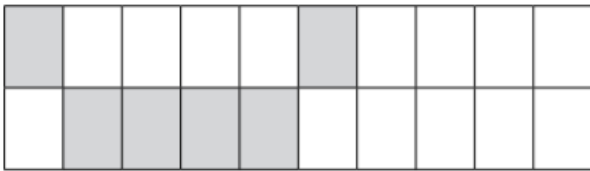

shaded to blank

d.

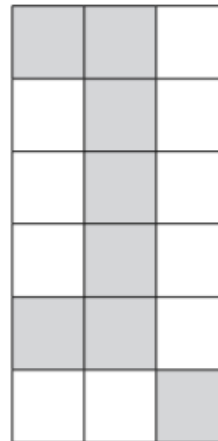

shaded to blank

Continue the sequences, counting on in multiples of the first numbers to find equivalent ratios. The first one is done for you.

<b>a.</b>	1:2	2:4	3:6	4:8	5:10	6:12
<b>b.</b>	1:4	2:8				
<b>c.</b>	2:3					
<b>d.</b>		10:14	15:21			
<b>e.</b>		4:22	6:33			
<b>f.</b>	3:7		9:21			

Esther is building a tower of cubes.

The ratio of red to yellow cubes is 3 : 1

The tower has 6 yellow cubes. How many red cubes are there?

Nijah plays 21 games of chess.

For every 2 games she wins, she loses 5 games.

How many more games does she lose than win?

a) Huan is making a drink by mixing 1 part juice with 5 parts water.

Complete the table to show the amounts he would need to use.

Juice	Water
1 litre	5 litres
2 litres	
4 litres	
100 ml	
200 ml	
300 ml	
	30 litres
	750 ml

b) Huan makes 1 litre 500 ml of drink in total.

How much juice and water does he need to use?

juice

water

## Spicy

For each grid write the ratio as you see it, then write the ratio in its simplest form. Show your working out. The first one is done for you.

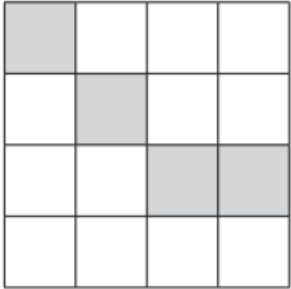
a. 

shaded to blank

$4:12$

$\swarrow$   $\searrow$

$\div 4 = 1$   $\div 4 = 3$

**1:3**

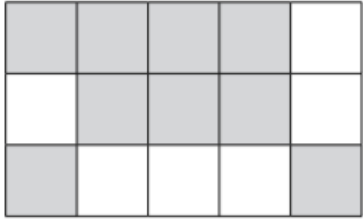
b. 

shaded to blank

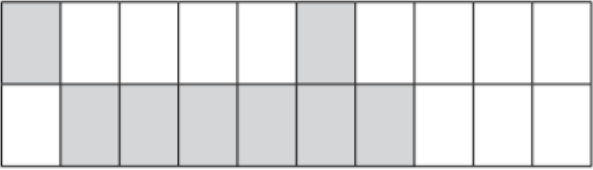
c. 

shaded to blank

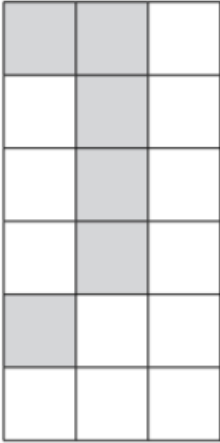
d. 

shaded to blank

Continue the sequences, counting on in multiples of the first numbers to find equivalent ratios. The first one is done for you.

a.	1:2	2:4	3:6	4:8	5:10	6:12
b.	1:5	2:10				
c.	2:7					
d.	3:5			12:20		
e.		14:22				42:66
f.				20:28		30:42

A group of students study French or German in the ratio 3 : 7

- a) Which subject has the most students? \_\_\_\_\_
- b) Draw a diagram to represent this.

- c) There are 80 students in total.

How many more students study German than French?

Wednesday

<https://www.bbc.co.uk/bitesize/tags/zncsscw/year-6-lessons/1>

<https://whiterosemaths.com/homelearning/year-6/>

Use scale factors to enlarge shapes

Fluent in 5

1	$8.4 + 2.3 =$ 	<input data-bbox="1114 909 1177 976" type="checkbox"/> 1 mark
---	---	--

2	$\frac{6}{10} - \frac{2}{5} =$ 	<input data-bbox="1114 1402 1177 1469" type="checkbox"/> 1 mark
---	--	--

3	$4.3 \times 3 =$ 	<input data-bbox="1114 1895 1177 1962" type="checkbox"/> 1 mark
---	--	--

4

$456 \div 19 =$



2 marks

5

$453.21 + \text{[ ]} = 843.24$



1 mark

6

$6^2 \times 2 + 3$

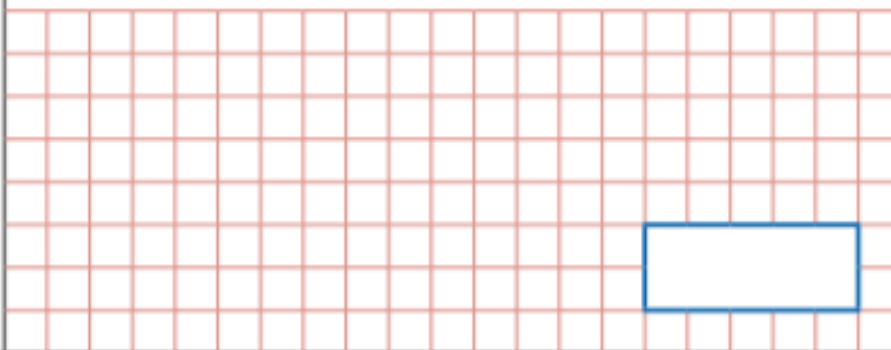

1 mark

## What Is A Scale Factor?

The scale factor is the number that is multiplied by the scale of an object to get another object that looks the same but is a different size; either scaled up or down.

## How Do I Enlarge An Object By A Scale Factor?

To enlarge an object by a scale factor, you must measure each side of the object, then multiply that number by the scale factor number.

For example:

You're given a square that is  $2 \times 2$ cm

Increase the square by a scale factor of 2

To do this, multiply each side by 2.

You then end up with a square that is  $4 \times 4$ cm

For example, this rectangle has the measurements 5cm and 2cm (not shown to scale):



If we increase this rectangle by a scale factor of 2, we double both the sides:

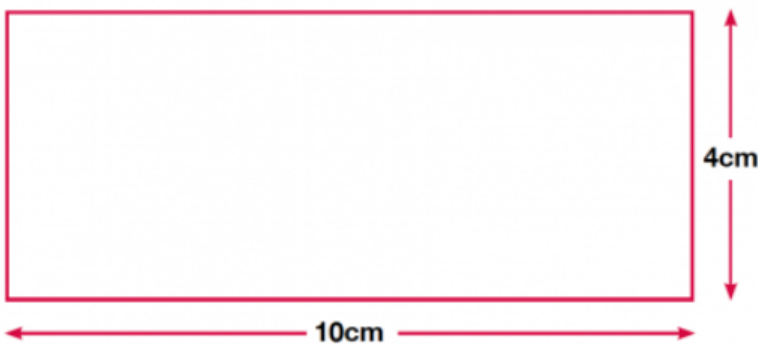

If we increase the original rectangle by a scale factor of 3, then we multiply each measurements by 3 to end up with this shape:

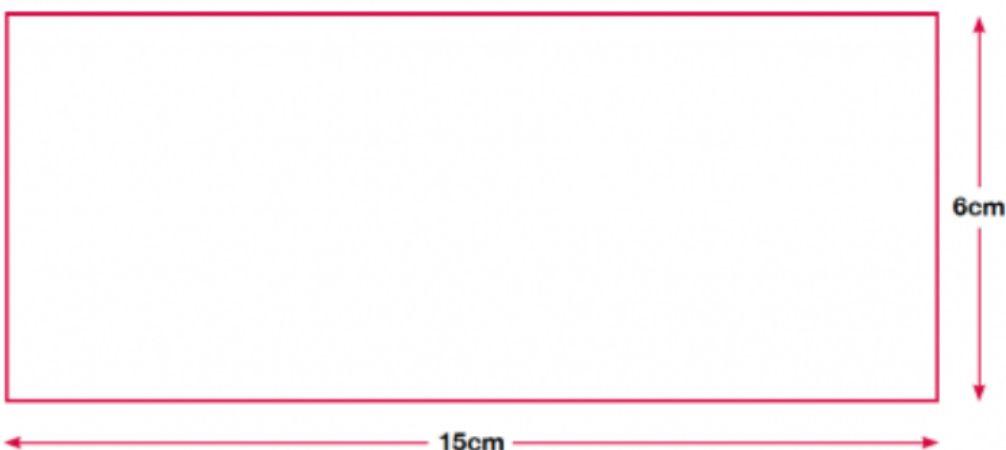

A triangle was increased by a scale factor of 3 resulting in this new shape:

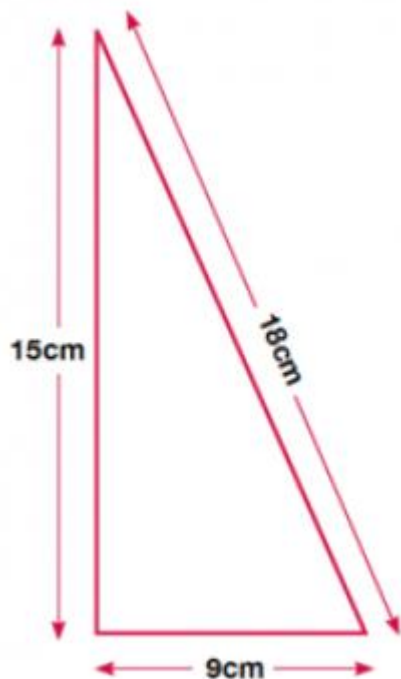

What were the measurements of the original triangle? For this problem you have to 'work backwards' and divide each side by 3

Answer: 3cm by 5cm by 6cm

**Mild**

Complete the sentence below. Shape A has been increased by a scale factor of \_\_\_\_\_ to create shape B.

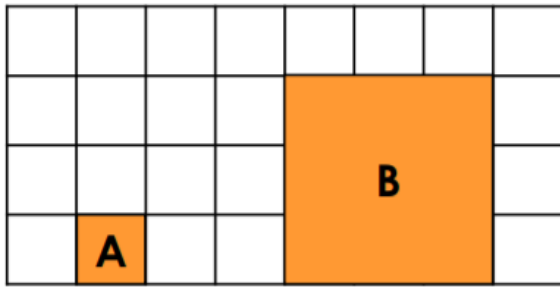

Will says he has enlarged his shape by a scale factor of 2. Shape B is his new shape.

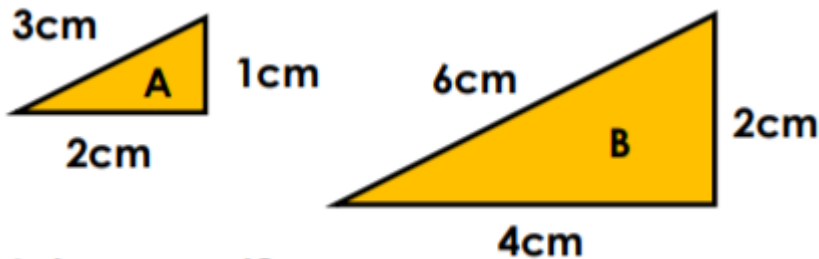

Is he correct?

Rectangle B has been scaled from rectangle A. Find the missing length.

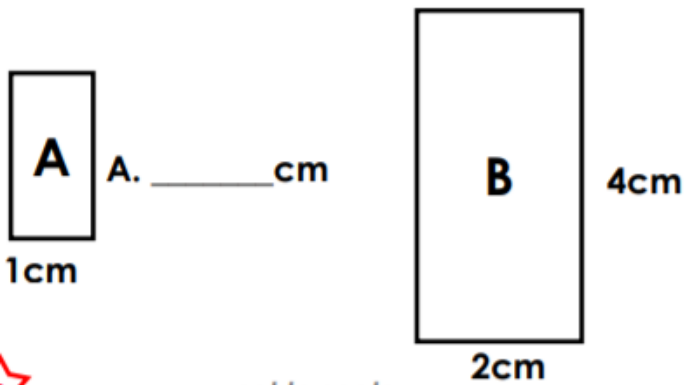

Triangle B has been scaled from triangle A. Find the missing length.

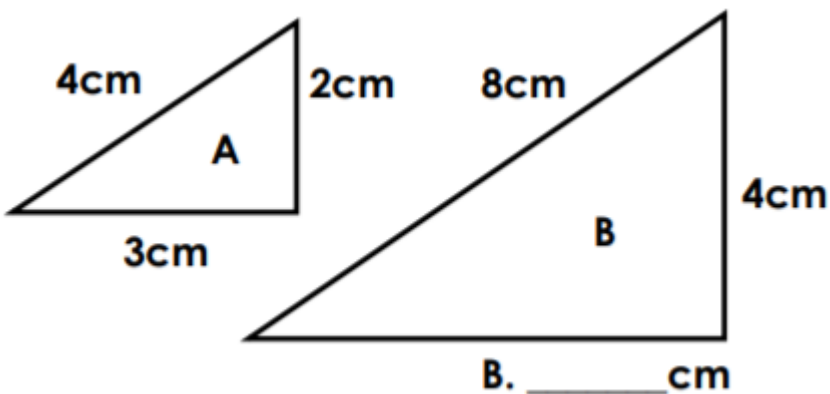

1 a) Here is a rectangle.

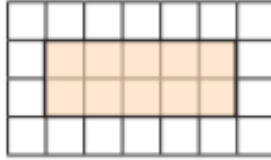

Draw another rectangle where each side is twice as big.

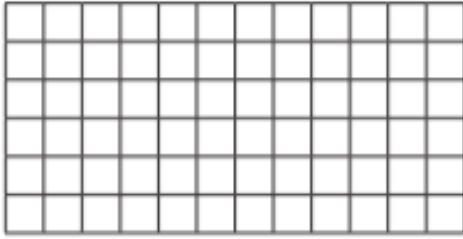

b) Here is a square.



Draw another square where each side is 4 times as big.

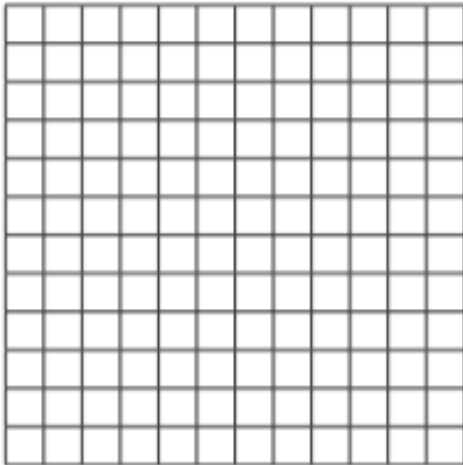

Sharon is enlarging shapes by a scale factor of 2 each time. She says that if she created shape C, one side would have a length of 6cm.

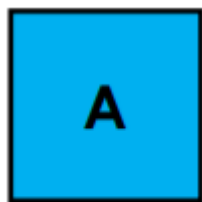

2cm

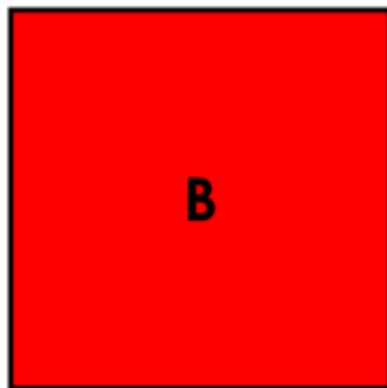

4cm

Do you agree? Explain your answer

**Medium**

- a) Explain what it means for a shape to be enlarged by a scale factor of 2

---

---

- b) Enlarge the shapes by a scale factor of 2

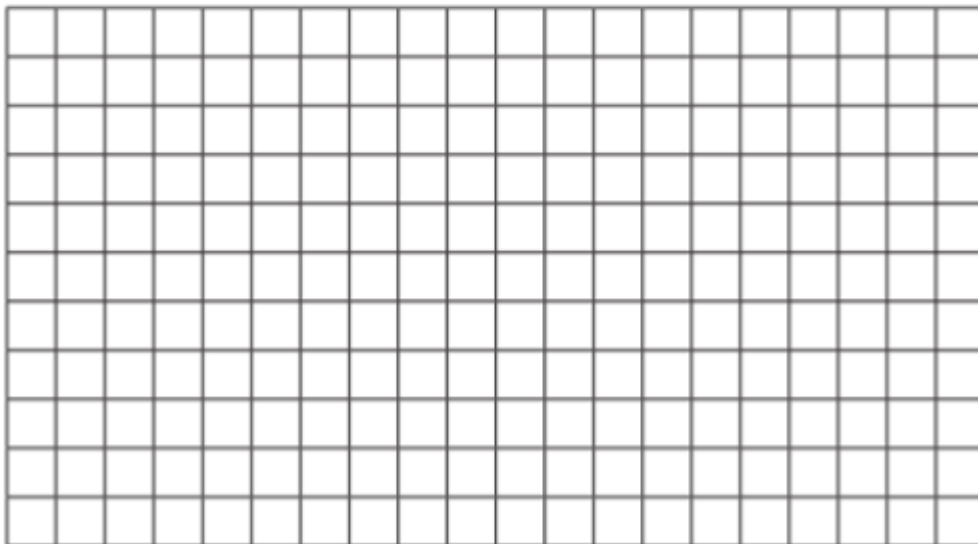
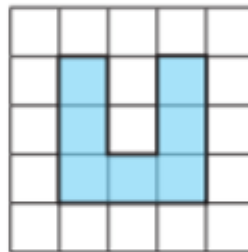
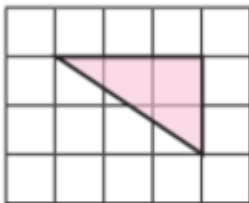

Complete the sentence.

A shape in which each side has tripled in size has been enlarged by a scale factor of

True or false? Shape A has been increased by a scale factor of 3 to create shape B.

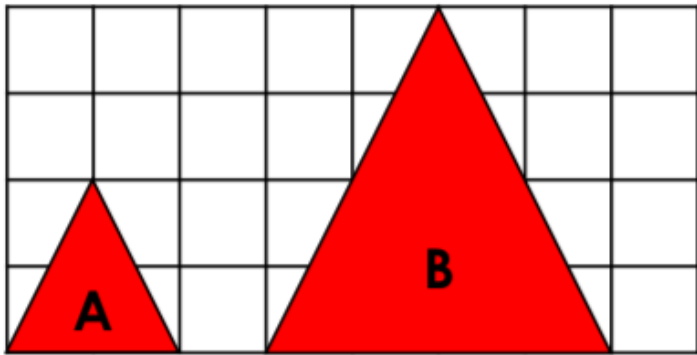

Triangle B has been scaled from triangle A. Find the missing lengths.

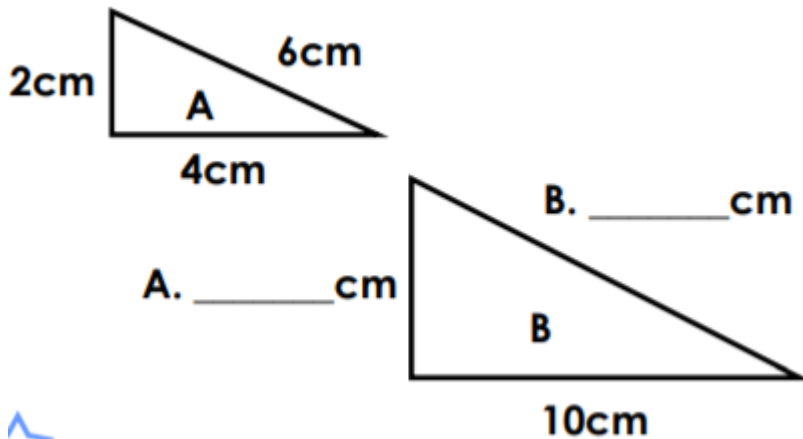

Triangle B has been scaled from triangle A. Find the missing lengths.

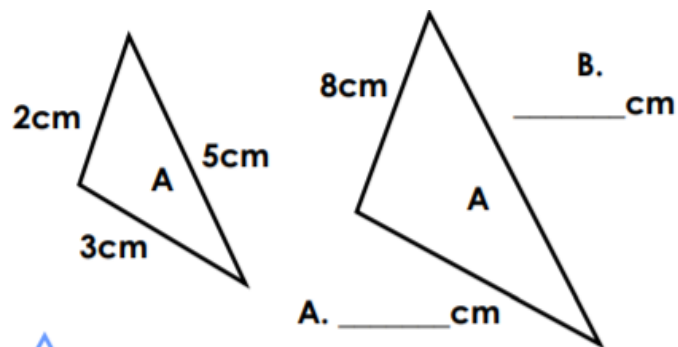

The sides of the rectangle are increased by a scale factor of 2

What is the perimeter of the new shape?

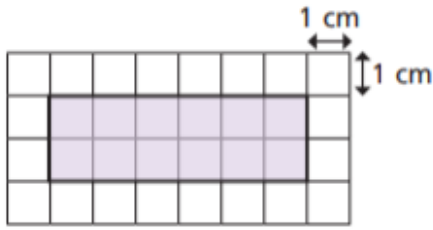

Eleanor has enlarged shape A to create shape B. She says if she created shape C using the same scale factor, one side would have a length of 5cm.



1cm

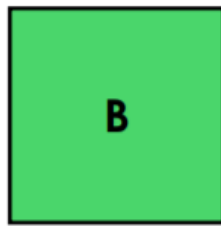

3cm

Do you agree? Explain your answer.

When enlarged, the perimeter of the shape below increases to 24cm.

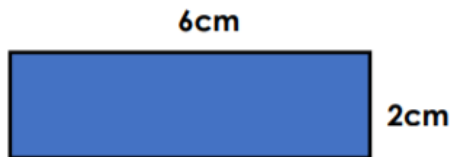

What scale factor has the shape been increased by? Explain your answer.

**Spicy**

True or false? Shape A has been increased by a scale factor of 2 to create shape B.

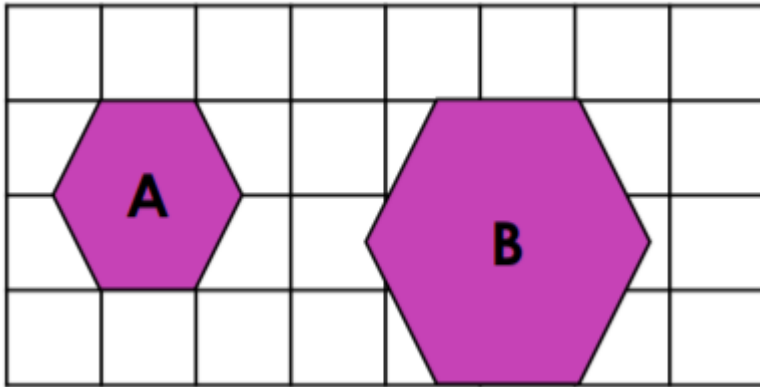

True or false? Shape A has been increased by a scale factor of 1.5 to create shape B.

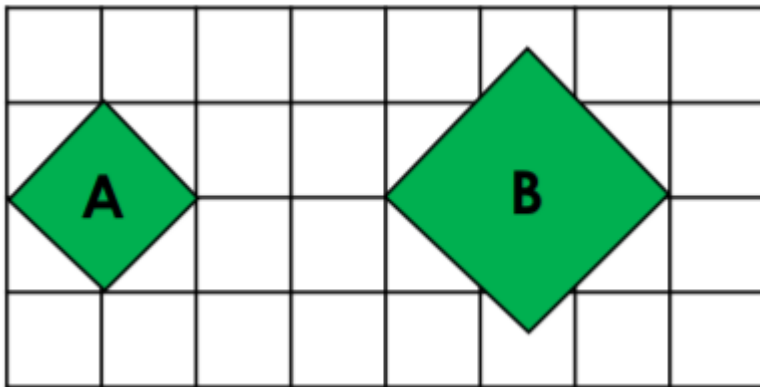

The shape has been enlarged by a scale factor of  $1\frac{1}{2}$

Fill in the dimensions of the new shape.

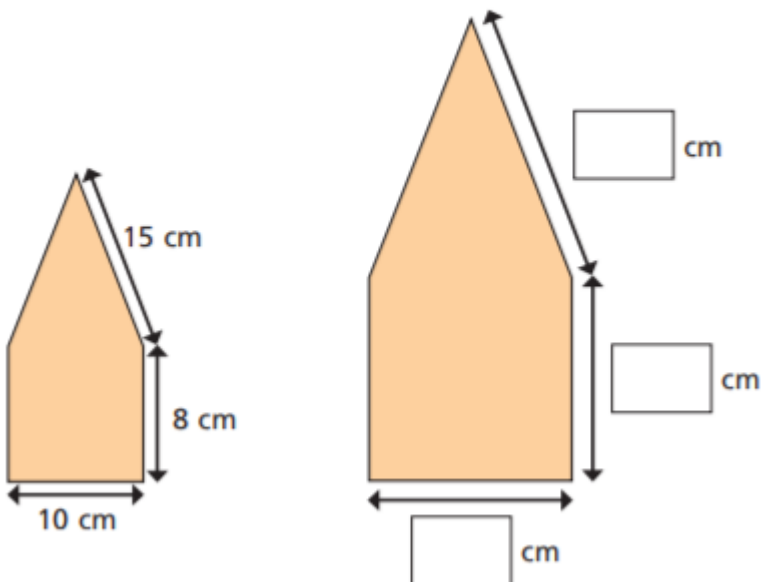

Triangle A has been enlarged by a scale factor of 5 to make triangle B.

Find the perimeter of each triangle.

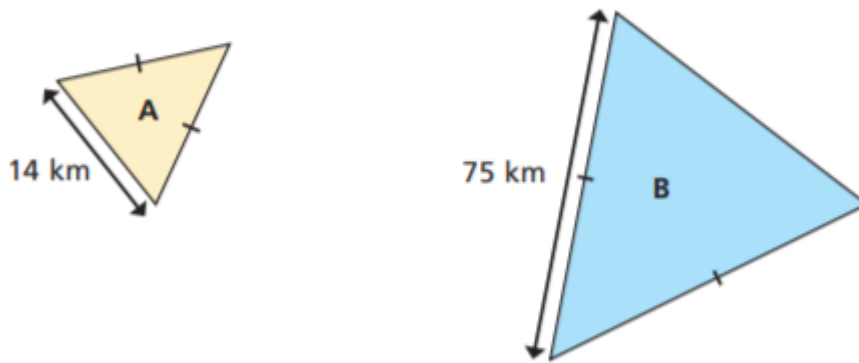

perimeter of A =  perimeter of B =

4 The two triangles are similar.

Find the length of  $a$ .

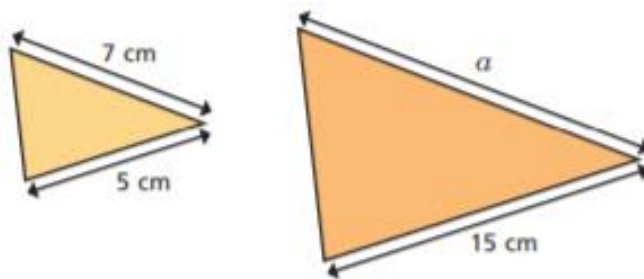

$a =$   cm

5 The two triangles are similar.

Find the area of the smaller triangle.

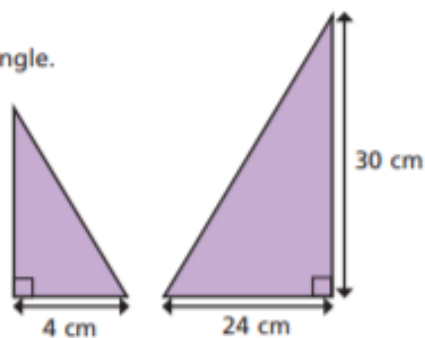

area =   $\text{cm}^2$

6 These two children's toys are similar.

Find the length marked  $y$ .

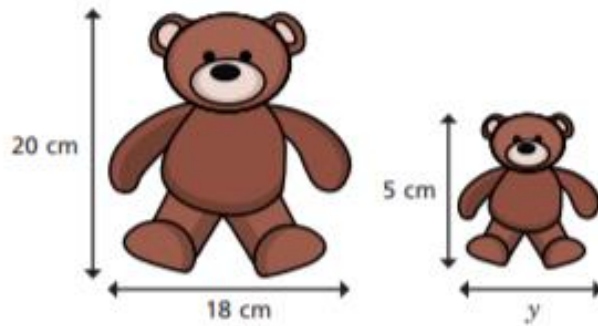

$$y = \boxed{\phantom{00}} \text{ cm}$$

When enlarged, the perimeter of the shape below increases to 49cm.



**What scale factor has the shape been increased by? Explain your answer.**

Jonny has enlarged shape A to create shape B. He says if he created shape C using the same scale factor, one side would have a length of 4.5cm.

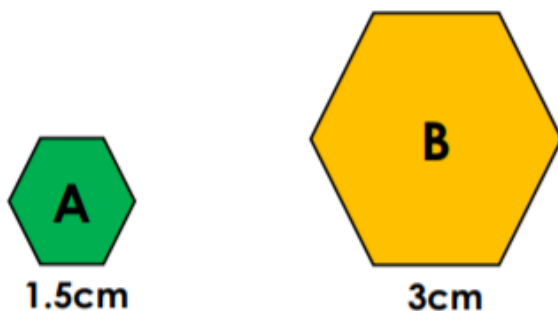

**Do you agree? Explain your answer.**

# Thursday

<https://www.bbc.co.uk/bitesize/tags/zncsscw/year-6-lessons/1>

<https://whiterosemaths.com/homelearning/year-6/>

Solve problems involving ratio in different contexts

Fluent in 5

1	$780 \div 100 =$	
		<input style="width: 100px; height: 20px;" type="text"/> 1 mark

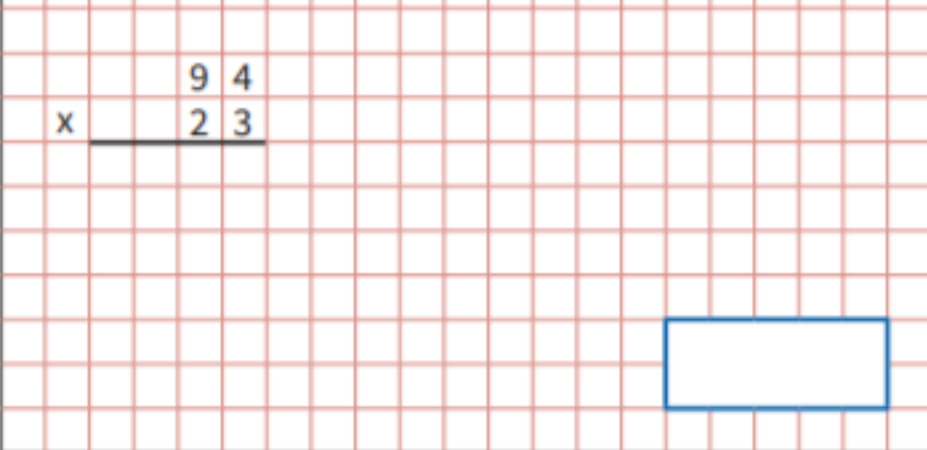
2	$\begin{array}{r} 94 \\ \times 23 \\ \hline \end{array}$	
		<input style="width: 100px; height: 20px;" type="text"/> 2 marks

3	$(3 + 8) \times 3 + 2 =$	
		<input style="width: 100px; height: 20px;" type="text"/> 1 mark

4

$+ 84.32 = 193.22$



1 mark

5

$8.1 \div 0.9 =$



1 mark

6

$\frac{3}{5} \times 5 =$



1 mark

**Mild**

1 Whitney buys 6 cans of lemonade for £3

a) How much do 12 cans cost?

b) How much do 3 cans cost?

c) How much do 15 cans cost?



2 The ratio of red to green grapes in a bowl is 3 : 1

a) Explain what this means.

---

---

b) There are 12 more red grapes than green grapes.

What is the total number of grapes in the bowl?

Write the correct answer:

1. Beef must be cooked for 30 minutes for every 1kg. How long would it take to cook:

2 kgs? \_\_\_\_\_

4 kgs? \_\_\_\_\_

6 kgs? \_\_\_\_\_

8 kgs? \_\_\_\_\_

2. To make 1 litre of jam, I use 100 strawberries.  
How many strawberries do I need to make:

2 litres? \_\_\_\_\_      3.5 litres? \_\_\_\_\_

3. I need to collect 30 stickers. Each bag of crisps contains 3 stickers.  
How many bags will I need to buy?

\_\_\_\_\_

4. The mother bear is fed 4 fish for every 2 fish that her cub is fed. How many fish would the cub get if the mother is fed:

10 fish? \_\_\_\_\_      20 fish? \_\_\_\_\_

5. There are 10 boys for every 30 girls at the disco.  
How many boys are there if there are:

60 girls? \_\_\_\_\_      90 girls? \_\_\_\_\_

## Medium

Amir is making some chocolate chip biscuits.

He has this list of ingredients to make 6 biscuits.

**Chocolate chip biscuits (makes 6)**

120 g butter  
72 g sugar  
180 g plain flour  
60 g chocolate chips

a) How much of each ingredient does Amir need to make 2 biscuits?

butter  g

plain flour  g

sugar  g

chocolate chips  g

b) How much of each ingredient does Amir need to make 10 biscuits?

butter  g

plain flour  g

sugar  g

chocolate chips  g

c) Amir has 240 g of chocolate chips.

What is the maximum number of biscuits he can make?

Dexter has some 20p and 50p coins in a jar.

For every three 20p coins he has one 50p coin.

There are 12 coins in the jar in total.

How much money is in the jar?

A drink is made using 3 parts orange juice to 2 parts lemonade.

Esther makes 1.2 litres of this drink.

How much orange juice does she need?

Write the correct answer:

1. Beef must be cooked for 40 minutes for every 1kg. How long would it take to cook:

2 kgs? \_\_\_\_\_

4 kgs? \_\_\_\_\_

6 kgs? \_\_\_\_\_

8 kgs? \_\_\_\_\_

2. To make  $\frac{1}{2}$  litre of jam, I use 50 strawberries. How many strawberries do I need to make:

2 litres? \_\_\_\_\_ 3 litres? \_\_\_\_\_

3. I need to collect 80 stickers. Each bag of crisps contains 4 stickers. How many bags will I need to buy?

\_\_\_\_\_

4. The mother bear is fed 5 fish for every 2 fish that her cub is fed. How many fish would the cub get if the mother is fed:

10 fish? \_\_\_\_\_ 20 fish? \_\_\_\_\_

5. There are 6 boys for every 9 girls at the disco. How many boys are there if there are:

27 girls? \_\_\_\_\_ 72 girls? \_\_\_\_\_

## Spicy

Write the correct answer:

1. Beef must be cooked for 40 minutes for every 1kg. How long would it take to cook:

2 kgs? \_\_\_\_\_

5.5 kgs? \_\_\_\_\_

6.25 kgs? \_\_\_\_\_

8.75 kgs? \_\_\_\_\_

2. To make  $\frac{3}{4}$  litre of jam, I use 45 strawberries. How many strawberries do I need to make:

2 litres? \_\_\_\_\_

3.5 litres? \_\_\_\_\_

3. I need to collect 66 stickers. Each bag of crisps contains 3 stickers. How many six-pack bags will I need to buy?

\_\_\_\_\_ How many bags will be left over? \_\_\_\_\_

4. The mother bear is fed 6 fish for every 3 fish that her cub is fed. How many fish would the cub get if the mother is fed:

18 fish? \_\_\_\_\_

26 fish? \_\_\_\_\_

5. There are 6 boys for every 9 girls at the disco. How many boys are there if there are:

54 girls? \_\_\_\_\_

144 girls? \_\_\_\_\_

Two shops sell the same cereal but in different-sized boxes.

<b>Shop A</b> 500 g of cornflakes £2.10
---

<b>Shop B</b> 750 g of cornflakes £3.30
---

Which shop is better value for money? Shop \_\_\_\_\_

Explain why.

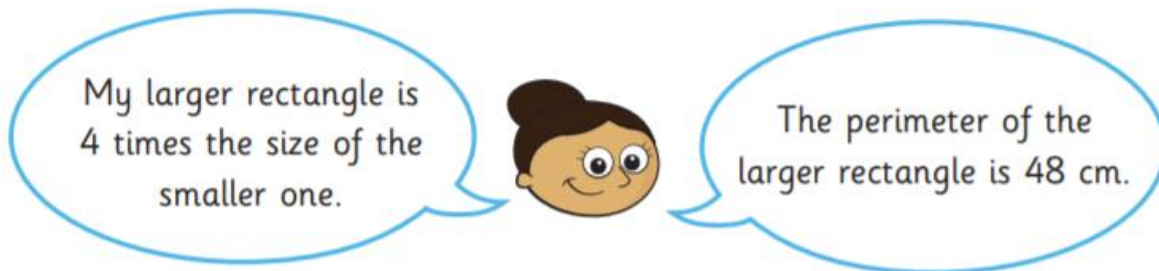

The length and width of both rectangles are even numbers.

What is the largest possible area for the small rectangle?

Aisha has two boxes of sweets.

- In the first box, the ratio of red sweets to green sweets is 3 : 1
- In the second box, for every 2 orange sweets there are 3 yellow sweets.
- There is the same number of sweets in each box.
- There are 12 yellow sweets in the second box.

How many sweets are in the first box?

# Friday

<https://www.bbc.co.uk/bitesize/tags/zncsscw/year-6-lessons/1>

## Challenge of the Week

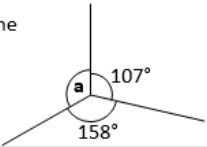
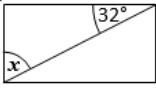

### Key Skills

#### Mild

A: Place Value, Add and Subtract		B: Multiply, Divide and Fractions		C: Geometry and Problem Solving	
1. What is the value of the <b>1</b> in this number? 7,186,354	5:1	11. Circle all the <b>multiples</b> of 25. 5   40   75   100	5:8	21. A race track is 2.654 kilometres in length.	5:18
2. Write <b>three hundred and ten thousand, five hundred</b> in digits.	5:1	12. Circle the <b>composite (non-prime)</b> numbers?   21   23   32   37   43	5:9	In a race, cars much do 3 laps. How long is the race?	
3. Round 596,147 to the <b>nearest hundred thousand</b> .	5:2	13.                    2,169 ÷ 3	5:10	22. Which of these is the largest?	5:19
4. What is the missing number? 500,350   600,350 <input type="text"/> 800,350	5:2	14.                    0.205 × 10	5:11	a. 0.85            b. $\frac{7}{10}$ c. 65%	
5. Find the difference in temperatures. <input type="text"/> London 0°C <input type="text"/> Glasgow -3°C	5:3	15. Complete this sequence of <b>cube numbers</b> .   1 <input type="text"/> 27   64	5:12	23. Draw an angle of 125°.	5:25
6. Write this number in Roman Numerals: 612	5:4	16. Write $\leq$ , $=$ or $>$ to make this correct: $\frac{6}{10}$ <input type="text"/> $\frac{21}{40}$	5:13		
7.                    24,148 – 16,200 =	5:5	17. Find an <b>equivalent fraction</b> of $\frac{45}{100}$ . 	5:14	24. Calculate the missing angle labelled <b>a</b> : 	5:26
8.                    137,449 + 25,658 =	5:5	18. Write $3\frac{7}{15}$ as an <b>improper fraction</b> .	5:15	25. A diagonal has been drawn through this rectangle. Calculate the angle labelled <b>x</b> . 	5:27
9. Complete this sum without written working. 38,700 + 11,300 =	5:6	19. $\frac{3}{9} \times 45 =$	5:16		
10. 17,293 seats out of 25,000 are taken. How many are empty?	5:7	20. Round 3.19 to the nearest whole number.	5:17		
<b>Total (A)</b>		<b>Total (B)</b>		<b>Total (C)</b>	
Test Total (A+B+C)		R (0-9)	Y (10-19)	G (20-25)	

# Key Skills

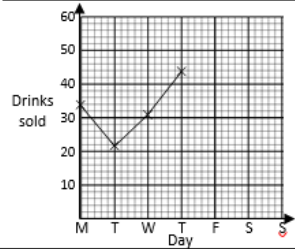
## Medium and Spicy

A: Place Value, Add, Subtract, Multiply and Divide		B: Fractions, Ratio, Proportion and Algebra		C: Measure and Problem Solving									
1. Write <b>one million, three hundred and eleven thousand, and six</b> in digits.	6:1	11. Which is the <b>largest</b> fraction? $\frac{2}{7}$ , $\frac{3}{14}$ or $\frac{7}{28}$	6:7	21. Name the shape: "I have 4 sides equal in length but no right angles".	6:24								
2. What is the value of the <b>7</b> in this number? 1,383,721	6:1	12. $\frac{3}{4} + \frac{2}{5} =$	6:8	22. The <b>diameter</b> of a circle is 18cm. How long is the <b>radius</b> ?	6:25								
3. Round <b>8,523,912</b> to the nearest <b>hundred thousand</b> .	6:1	13. Simplify your answer. $\frac{2}{7} \times \frac{5}{6} =$	6:9	23. Calculate the value of <b>a</b> . 	6:26								
4. To a number I add 7 then subtract 9 and get -3. What did I start with?	6:2	14. $3.121 \times 10$	6:10	24. Complete the line graph for drinks sold by a market stall: <table border="1" data-bbox="1037 660 1372 705"> <thead> <tr> <th>Day</th> <th>Fri</th> <th>Sat</th> <th>Sun</th> </tr> </thead> <tbody> <tr> <td>Drinks sold</td> <td>52</td> <td>60</td> <td>36</td> </tr> </tbody> </table> 	Day	Fri	Sat	Sun	Drinks sold	52	60	36	6:29
Day	Fri	Sat	Sun										
Drinks sold	52	60	36										
5. $3,174 \times 63$	6:3	15. $5.24 \times 4$	6:11										
6. Give your answer to the <b>nearest whole number</b> : $1,602 \div 13$	6:3	16. Write this decimal as a <b>fraction</b> and a <b>percentage</b> . <span style="border: 1px solid black; border-radius: 50%; padding: 2px;">0.25</span>	6:12										
7. Which is a <b>common multiple</b> of 16 and 24? 16 24 48 54 60	6:4	17. Find <b>30%</b> of 90.	6:13										
8. Circle <b>all</b> the <b>prime numbers</b> : 71 73 75 77	6:4	18. What is the <b>scale factor</b> ? 	6:14										
9. $48 \div 8 + 6 \times 7$	6:5	19. How long does a 5kg chicken take? <span style="border: 1px solid black; border-radius: 10px; padding: 2px;">To cook: 1 hour + 15mins per kg.</span>	6:15										
10. How much cheaper is a meal? <span style="border: 1px solid black; border-radius: 5px; padding: 2px;">Burger £2.49</span> <span style="border: 1px solid black; border-radius: 5px; padding: 2px;">Fries £1.19</span> <span style="border: 1px solid black; border-radius: 5px; padding: 2px;">Meal £3.20</span>	6:6	20. What is the rule for this sequence? 5, 11, 17, 23, 29, ...	6:16	25. Find the mean of these numbers: 10 7 4 12 9 18	6:30								
Total (A)		Total (B)		Total (C)									
Test Total (A+B+C)		R (0-9)		Y (10-19)      G (20-25)									

